

INTO THE VOID

By Carl Smith
ARES #15 pp 53-60

STAR FRONTIERS: ALPHA DAWN™ and STAR FRONTIERS: KNIGHTHAWKS™ are role-playing rules of conquest and combat in outer space. Man and allied extraterrestrials stand side by side to fight the menace of the dreaded Sathar.

The Sathar are an evil and warlike race. Resembling giant, multi-legged worms, they have infiltrated the United Planetary Federation (UPF). The Sathar's goal is to destroy the UPF and all non-Sathar life forms, and they use traitors and the technology of tomorrow to achieve it. Only a few adventurers and professionals stand between the Sathar and the fate of the universe.

To play this game, players need the original STAR FRONTIERS: ALPHA DAWN and the new STAR FRONTIERS: KNIGHTHAWKS. Also needed are three 10-sided dice and scratch paper. Beyond that, add a little creativity and imaginative role-playing, and begin your adventure in the future.

This mini-module is meant for the referee. It is based on the short story, "Into the Void," in this issue. If you intend to play a character in this module, read no further. (Sections meant to be read aloud are in **bold colored boxed text.**)

The scenario begins aboard a freighter, the United Planetary Federation's *Prachil Star*. It is homeworld bound, carrying cargo from several systems. In one cargo hold, it carries a precious burden: an experimental escape vessel prototype. Because of the prototype's nature, several agents of the Pan-Galactic Corporation (PGC) have been assigned to guard it while it is in transit.

Pirates have attacked several ships in this area, and the possibility exists that Sathar agents would like to steal the experimental ship for its compact void drive system.

Members of the PGC are to guard the vessel, see that it does not fall into unauthorized hands, keep unauthorized personnel out of the cargo bay where it is stored, and repulse anyone seeking to sabotage or steal the prototype.

Colonel Gaedynn is commander of the PGC force aboard the *Prachil Star*. Other members of the PGC are on board the freighter, but are not with the group at the cargo bay. The adventurers have just reported for a four-hour shift of duty.

CARGO BAY WHERE THE XV-1 IS STORED

The cargo bay is bare metal. A few common tools lie on a work bench near the cargo doors. An emergency repair kit for the hull of the freighter lies under the work bench. The XV-1 is the only item in the cargo hold other than the tools and repair kit that is not a molded part of the freighter's hull.

Above the door are a speaker and the emergency light. In case of attack, or depressurization of the outside corridor, the light and its accompanying alarm come on. Using the speaker and the on-off switch, a person inside can communicate with someone outside of the cargo bay without opening the cargo door.

A button on a panel to the left of the cargo door controls the two-way speaker. Just below that button are three other buttons which control the door. They read "Open", "Close", and "Lock". Once locked, only a security card and thumbprint can open the door from the outside. From inside, the door can be opened by simply depressing the "Lock" button a second time. When the door is locked, the "Lock" button is red. When unlocked, the button is unlit.

The XV-1 faces the front of the *Prachil Star*. Its starboard airlock is next to the outside bulkhead of the freighter. Anyone on the starboard side of the XV-1 cannot see the cargo bay door.

The floor of the cargo bay has mini-stanchions every ten feet. A safety line can be secured to the stanchions for zero-gravity cargo. A player in a space suit can secure his safety line to one of the stanchions by snapping it on for zero-gravity repairs inside the cargo bay.

BATTLE IN THE CORRIDOR

Everyone has a duty station. Listed below is where the PCs can be stationed prior to the beginning of this encounter:

Capt. Llewellyn	Inside cargo bay doors
Hota Lea	Inside XV-1
Violet (robot NPC)	Inside XV-1
Dorf	By starboard airlock of XV-1
Gillimk	By starboard airlock of XV-1
Viyizzi	By port airlock of XV-1
Yoe	By port airlock of XV-1
Slard (NPC)	In corridor outside cargo bay
Col. Gaedynn (NPC)	In corridor outside cargo bay

During this four-hour watch, the ship is attacked. To find out when it is attacked, roll 1d4 for the hour of the watch. If the attack occurs during the first hour, give the diagram of the XV-1 to the adventurers inside the vessel in the cargo area. Do not let others see it until they enter the XV-1.

If the attack occurs in the second, third, or fourth hour, let everyone look at the XV-1 plan. No NPCs are inside the cargo bay, and PCs are never stationed outside the cargo bay.

Every hour, have one of the PCs go outside the cargo bay to check the NPC on guard duty. When the attack occurs, the PC opens the door and is fired upon by a mercenary NPC.

SATHAR AND MERCENARY STATISTICS

Typical Sathar

Str/Sta 45/45 **Dex/Rs 35/35**
Int/Log 40/40 **Per/Ldr 55/55** **Im 4**
Walk/Run/Hour **10m/30m/5km**

Typical Mercenary

Str/Sta 40/40 **Dex/Rs 40/40**
Int/Log 45/45 **Per/Ldr 40/40** **Im 4**
Walk/Run/Hour **10m/30m/5km**

Eight Sathar, each armed with a laser rifle, are aboard the *Prachil Star*. Each Sathar commands six mercenaries (total 48). Three (of the six) are armed with projectile rifles and pistols; one has a grenade launcher and a pistol, and the other two have laser pistols and rifles. Each mercenary has three magazines for each weapon. The mercenary with the grenade launcher has four grenades. Two of the Sather-led groups have a heavy laser each. When the PC goes into the hall, start the attack. Read the following to the PCs:

The *Prachil Star* shudders and throbbing floorplates shake the cargo bay. The red light over the door of the cargo bay goes on, and an alarm begins whining - it's the battle alarm. A figure in a PGC uniform kneels in the corridor. Beside him lies another figure, an officer who is not moving. The figures are under fire from someone at the end of the corridor. There is a buzz, the metal of the cargo bulkhead glows, and then blackens. Several figures at the end of the corridor fire laser and projectile weapons.

If the PC checks the two in PGC uniforms, he discovers that Col. Gaedynn lies dead at Sgt. Slard's feet. The Sathar down the hall are firing at Slard and the PC.

There are two Sathar and three mercenaries. The Sathar have lasers, and the mercenaries are armed with projectile weapons. At this range, they have a flat chance of hitting Slard or the PC on 10% with Laser or 05% with Gun.

Every turn equals six seconds. For each turn the PC and Slard remain in the hall, a mercenary joins the troops firing at them. The first five have projectile weapons, the sixth has a laser, and this pattern is repeated as long as PCs stay in the corridor.

If Slard or any PC is hit, they take a standard 1d10 of damage, because all weapons are set on their lowest setting to minimize chances of damaging the XV-1.

Attackers keep coming until Slard and the PC retreat to the door of the cargo bay. If anyone stays in the corridor for more than two minutes, he comes under fire from the corridor behind him. Sathar agents have worked their way behind the PCs by way of the port cargo door corridor. Any shots fired by the five Sathar attackers miss the first turn they sneak up behind the PCs. Thereafter, those Sathar behind the PCs stand the same chance of hitting as the Sathar in front of the PCs.

- 1 Observation Dome
- 2 Upper Bridge
- 3 Lower Bridge
- 4 Crew Quarters
- 5 Crew Quarters/Galley
- 6 Recreation Rooms/Sickbay
- 7 Maintenance/Repair
- 8-11 Cargo Holds
- *9 Cargo Bay where XV-1 is kept

OVERALL LENGTH: 315m
 OVERALL WIDTH: 166m
 OVERALL HEIGHT: 75m

CARGO POD LENGTH: 166m
 CARGO POD WIDTH: 64m
 ENGINE LENGTH: 154m

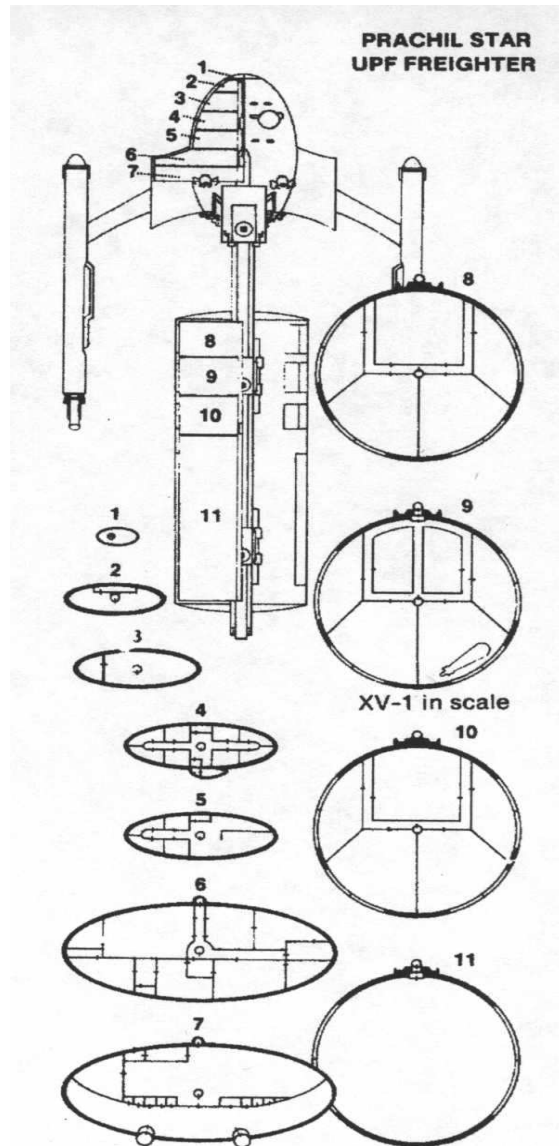

THE BATTLE IN THE CARGO BAY

Treat the cargo bay door as having 50 + 2d10 worth of structural points. The first turn after the PCs go inside the bay, the Sathar fire a grenade rifle at the cargo door. The grenade hits the wall beside the door, causing half its normal 8d10 damage to the door.

There is a loud, muffled explosion in the corridor. It sounds as if someone threw an explosive charge against the cargo door.

On the third turn, the Sathar use a heavy laser on the door. It is set to use 20 Standard Energy Units (SEU) per shot/turn. A Sathar continues shooting the heavy laser at the door until the door is burned through. The first turn after the door is burned through, the hole is too hot to enter. It is cool enough not to burn through space suits on every turn thereafter.

The door then begins to get warm. The metal changes colors, glowing, sagging, and turning molten. A 24-inch hole appears.

On the first turn the doors is burnt through, one Sathar mercenary may fire either laser or a projectile weapon through it per turn. Through the hole in the cargo door, the mercenaries can see only the port side of the XV-1.

Sathar mercenaries fire at targets in the following order:

- 1) Anyone close to the door.
- 2) Anyone in the cargo bay not near the XV-1.
- 3) Anyone in the port airlock of the XV-1 or hiding behind the vessel and shooting at them.
- 4) The XV-1 itself.

Players may fire at the Sathar or attempt to board the XV-1. To board the vessel, they must go to an airlock and step inside. They may not fire during that turn, as they need both hands to get aboard the XV-1.

PCs firing at any Sathar coming through or firing through the door do so with the penalty for firing at a target behind cover. Sathar receive a penalty for firing at PCs on the starboard side of the XV-1 (treat as hard cover).

INSIDE THE XV-1

PCs inside the XV-1 cannot see what is going on outside unless they are in either the pilot of co-pilot/gunner's seat. All PCs have some ship-handling skills, but Llewellyn is the best pilot, followed by Yoe.

It takes one turn to ready the XV-1's weapons, sublight, void, life support, and communication systems.

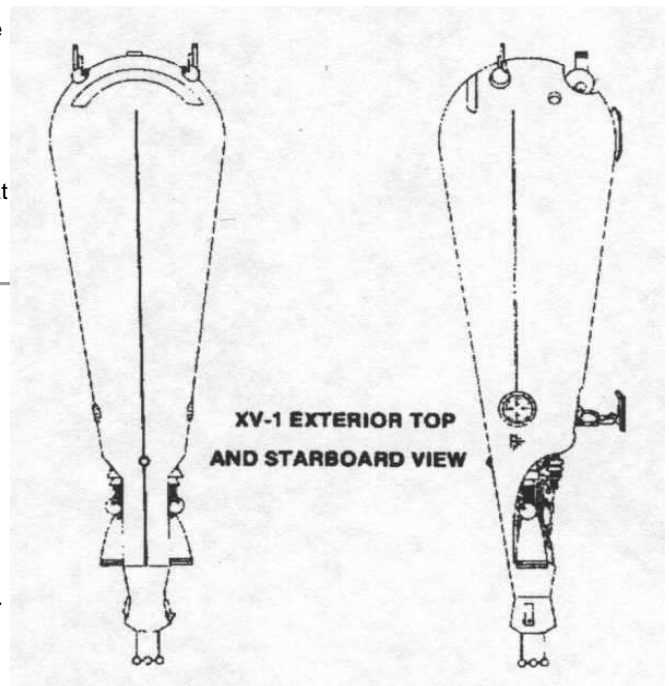

Using the console microphone, those inside can communicate with Llewellyn (or any PC) who is wearing an exo-suit (space suit) equipped with an intercom.

Once someone takes one of the two pilot's chairs, the others may choose any seat #3-7. Slard, an NPC, automatically takes seat #8.

Once aboard, Slard voices his uncertainty about the safety of the craft. He complains about the risk they are taking in using an untested experimental vessel, and how dangerous flying near the Sathar warships is once the XV-1 gets outside the *Prachil Star*.

Whoever is in the pilot or co-pilot's chair knows what is going on outside the XV-1. Tell that PC (and he can inform the others):

You see the PCs outside the ship moving away from the cargo door. The cargo door appears to be melting.

If the PCs switch on the vessel's power so its sensors can be used, they hear a PC say shots are being fired. Once the door has a hole melted through it, the sensors reveal life forms in the corridor outside the cargo bay.

The XV-1 is capable of sublight and void travel. Its console is no more complex than an orbital craft's.

Players inside the XV-1 should be made aware that they have very little chance of fighting their way through the corridor. If necessary, they may contact other areas of the freighter. The advice they receive from the other areas of the ship is to stay put and not attempt to enter the corridors.

Make the players aware of the capabilities of the FF laser cannon on the XV-1. The cannon has a possible 10,000 SEU at its disposal. It can be fired in increments as small as 10 SEU or as large as 100 SEU.

As soon as the players are aware that the FF laser cannon can destroy a portion of the wall, it is up to one of them to know that the XV-1 can blast a hole through it, and they can escape. If they do so, point out that one of the primary directives is to keep the XV-1 out of unauthorized hands.

The exterior wall of the ship has a value of $50 + 2d10$. If the PCs attempt to blast through the wall, the cannon is set at 50 SEU. To create a hole large enough for the XV-1 to pass through, the PC must get three hits on the wall, or a total greater than the value of the wall.

When the PC makes his first hit on the wall, the cargo bay depressurizes. Anyone or anything in the cargo bay or just outside its door is sucked into space unless secured to something or safely inside the XV-1. A safety line from a spacesuit can withstand the strain of depressurization, although the sudden loss of pressure will knock a secured PC off his feet.

Any PC outside the XV-1 after the decompression must fight in zero-gravity conditions, and make his way inside the escape craft. On the third turn after decompression, more Sathar mercenaries come to the door and begin firing at anyone in the cargo bay. They all have laser rifles set at 20 SEU.

Should the players be reluctant to blast a hole through the outer hull of the *Prachil Star* and escape, the Sathar and their mercenaries enter the cargo bay. The Sathar and mercenaries take two turns to reach the XV-1. Once they have reached it, they can open the airlocks by pressing the button on the outside. There is no effective way of "locking" it, although the airlock between the cabin and the entry room can be locked from the console; so can the airlock going into the engineering and tail section of the craft. The Sathar can open the "locked" airlocks by firing at them as they did with the door to the cargo bay. Each airlock has a structural value of $50 + 1d10$.

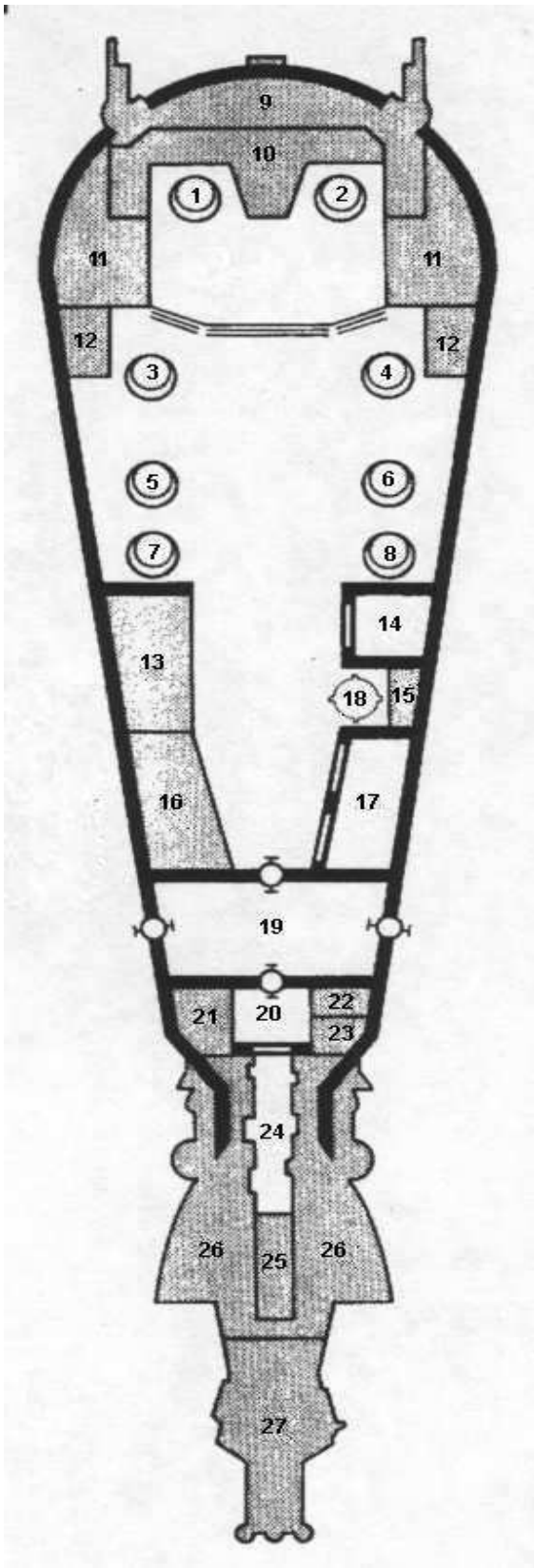

KEY TO THE XV-1

Locations on the XV-1 are numbered for specific locations. General areas are simply referred to as forward, or the passenger compartment; the airlock entry; or the rear section. The key to the deck plan is:

- 1 Pilot's Grav-Couch
- 2 Co-Pilot's/Gunner's Grav-Couch
- 3-7 Passenger Grav-Couch
- 8 Slard's Grav-Couch
- 9 Gunnery Control
- 10 Flight Control Console
- 11 Life Support Console
- 12 Shield Unit
- 13 Food Processing/Recycling
- 14 Chemical Toilet
- 15 Robotic Charging/Service Center
- 16 Medical and Exo-Scanner
- Computers
- 17 Exo-Suit Storage
- 18 Robotic Mooring Station
- 19 Airlock/Pressurization Area
- 20 Engineering Area
- 21 Astrogation Unit
- 22 Sunlight Communication
- Computer
- 23 Void Communication Computer
- 24 Sublight Drive Access Way
- 25 Life Support System
- 26 Sublight Drive Unit
- 27 Void Drive Unit

Total Length: 22m

DETAILED DESCRIPTION

Item #10, Captain's Control Console. On the console are tie-ins and screens for all computers. From this console are tie-ins and screens for all computers. From this console all interior airlocks and hatches can be locked, as well as all fired weapons and powered defenses. Radio communications outside the hull, to anyone in a space suit on the same band, sublight communication, and void communication originate with the radio here.

Item #15, Robotic Charging and Tie-in Computer. This unit allows Violet to tie-in directly with the XV-1's computers and to inform the crew the extent of any damage. The computer can also fix any damage to Violet requiring fourth level skills or less. Violet has the equivalent of three power-packs, and they can be recharged from this unit.

Item #16, Medical and Exo-Scanner Computers. Using these computers, the crew can determine if any accessible asteroid can support human life. Also, the medical computers can identify damage to characters, and recommend treatment. The computer has the equivalent of 10 doses each of stimdose, staydose, anti-tox, and telol; a freeze field with a 2,000 SEU power pack; and programs for first aid, diagnosis, minor surgery, and communication interpretation (a built-in polyvox). It has a success rate of 20% in identifying/treating any life form which is not a PC.

ITEM #17, Exo-Suit and Weapons Storage Locker. Inside are five laser rifles each with three power packs; three laser pistols with a total of 30 power packs; a heavy laser with four power packs and tripod; four machetes; two vibroknives and power packs; three automatic rifles with three magazines each; three automatic pistols with three magazines each and 2,000 rounds of pistol ammunition in a box; six holoflares; eight all-weather coveralls with arctic inserts; and three exo-suits with helmets.

When the PCs use the XV-1 to exit the freighter, they must do so at sublight drive speed. If they attempt to use void drive, the void computer automatically cuts the void drive off. A second attempt results in a flashing message from the computer: *Void drive cannot be activated in a confined space. Move to open space and reactivate void drive unit.*

ATTACK BY SATHAR FIGHTERS

Once outside the hull of the freighter, the PCs are attacked by Sathar Fighters and a Sathar Frigate. The Sathar ships fire bursts of increasing strength (10 SEU, 20 SEU, etc. . . .) until it is evident that the PCs do not intend to stop. The Sathar may increase their power to 100 SEU once the XV-1 fires on one of them and achieves a hit. After that happens, or when the PCs go into void drive, the Sathar Frigate fires its last torpedo.

The torpedo hits the XV-1, but does negligible damage. It damages three different areas of the XV-1 using the STAR FRONTIERS: KNIGHTHAWKS™ Advanced Damage/Location Table. None of the damage is multiple. If the d% indicates more than one hit in an area, roll again. If the void drive is hit, it is damaged. If no die roll results in damage to the void drive, assign damage there. The XV-1 goes into the void one time, and thereafter the void drive malfunctions as follows.

After the first void drive attempt, any further trials will force the XV-1 to jump backward 10,000 km. The XV-1 may successfully jump into the void as it fights the Sathar Fighters and Frigate the first time, and then it takes void drive damage. Thereafter, any attempts to jump the void results in the XV-1 going backward as outlined.

The XV-1 may take damage to the ammunition supply of its cannon. Treat each 100 SEU as one shot. Under no circumstance is the XV-1 to have less than two shots at the final scenario. Other ammunition may be destroyed, as long as 200 SEU remain.

INTO THE VOID

The XV-1 has jumped into the void successfully. It now lies far away from the ships attacking the *Prachil Star*. The portion of space it occupies is known to all aboard the vessel.

A vast expanse of space lies ahead. The astrogation computers show that the ship has jumped across space into the void.

If the PCs attempt to use the astrogation computers further, give them computer feedback that is gibberish. If the player's think to have the command console run a check on the XV-1's systems, reveal that they cannot fully access void drive, void communication, or astrogation.

If a player thinks to link Violet to the void computer, tell him that the system has sustained minimal damage.

Any further attempts to jump into the void result in the XV-1 jumping backward 1d6 x 10,000 km in a straight line. If the players do not think to jump backward after a reasonable period of time, let Hota Lea attempt to fix the computer. After a brief interval, she announces:

With the equipment we have onboard, attempting to fix the computer is like trying to fix void drive with a screwdriver.

Violet can diagnose what is wrong with the ship, if asked. She can also indicate what will happen if the PCs attempt to use the void drive, i.e., the XV-1 will jump backward up to 60,000 km. If asked to attempt to repair it, Violet answers:

I am one of the finest diagnostic medical robots available. I am not a surgical robot. I am not a robotic repair unit. The damaged circuit is in such a place on the panel that we would have to chance leaving the XV-1 a floating hulk, totally without power. The chances of such an operation succeeding with our limited repair facilities are 11 in 3,736, 941. The chances of compounding the damage with human error are prohibitive. It would be unwise to attempt repairs outside of a qualified and well-fitted repair facility.

Aboard the XV-1, all computers, drives, and numbered areas have an access panel from both the interior and exterior of the ship. To attempt repairs on any of these computers or drives requires a tech Level 5 repairing machinery, and a robotics skill Level 6 altering mission, as well as Level 6 repairing computers.

For sublight drive, a Level 3 repairing machinery is needed. Anyone with any operating machinery skill can fly this simple craft. In order to operate the FF cannon, a person must have a military skill with beam weapons, or the ability to operate machinery, as firing is integral to the operation of the XV-1.

SLARD, THE TRAITOR

Once the vessel has been explored, and the damage assessed, the NPC Slard begins having what the PCs may interpret as "second thoughts" about escaping the battle. He talks to them about how badly damaged the ship is, and how it might be wiser to seek an inhabited planet or habitable asteroid and send out a distress signal on all operating bands. Slard says:

I don't know how much damage this vessel can take. How do we know Violet's right? After all, it is primarily a medical robot - it might have made a mistake.

If the PCs think Slard's assessment is correct, Slard plays along with them until a suitable asteroid is found. To find a habitable asteroid, roll 1d10 every turn. A result of 1 means an asteroid capable of supporting life has been located.

If the PCs do not find an asteroid within ten turns, or if they do not agree to Slard's plan, he acts as if nothing is the matter. Soon as he has a chance, he secretly pulls out his weapon, a laser pistol, and orders the XV-1 to go in the direction from which they came: Slard says:

All right, listen to me. I am taking over command of this ship. We're going to turn her right around and go back where we came from. Nobody do anything foolish, and we'll all live a lot longer.

If PCs accuse Slard of being a Sathar agent, he tells them the truth: The Sathar want the XV-1 because they heard rumors about how well it works. They want it to use its drive system and computers on kamikaze fighters for attacks on UPF ships, bases, and planets. Slard says:

What's a traitor? I see which way things are going, and I want to be on the winning side. A traitor becomes a hero when his side wins - he's only a traitor if his side loses. The Sathar pay well, and they aren't going to lose.

Slard is alert. A player must have a reaction speed of better than 5 to catch Slard off-guard. If a PC with a reaction speed of 5 or less attempts to draw his weapon, Slard receives first shot at them.

Players in the grav-couches suffer a -20 to their dexterity. If they draw their weapon, they must also make their dexterity roll or Slard will fire first. A player attempting to draw his weapon, but failing his dexterity roll, still is able to fire. Failure means that he did not draw quickly enough to get first shot.

Players shooting at Slard may hit him. If so, consult the star frontiers chart for damage. If they miss Slard, check what is in their line of fire, and have them roll again to see if they hit anything. All interior items (with the exception of airlocks and separating walls, which have already been covered) have 25 + 1d10 of structural points. If the number of points is exceeded, the machinery or computer is damaged.

When fired upon, Slard returns fire at the nearest target firing at him, or moving toward him. If several targets are equidistant from Slard, he returns fire to the one most nearly in front of him.

Slard also has a doze grenade and a tangler grenade in his suit. On the second round of firing, he throws the doze grenade at those firing at him. On the following round, he throws the tangler grenade at the PCs in the pilot/co-pilot area.

Should Slard die or be incapacitated, the PCs become aware of a blip on the sensor screen. If they ask the computer, it reveals that the blip on the screen is most likely the Sathar Frigate which has followed them into the void.

ENCOUNTER WITH THE SATHAR FRIGATE

When the Frigate appears, the PCs notice a blip on their sensor screen. The Sathar vessel does not attack them at once. It prefers to take the XV-1 undamaged. Over the sublight intercom comes the message:

Surrender! You will be well treated. It is futile to resist. Further attempts at evasion will result in your vessel being destroyed. We offer you your lives.

The offer, of course, is only a ploy to capture the XV-1. The PCs who surrender will be brainwashed and sent back to the UPF as saboteurs. Should any resist, they will be executed on the spot.

If the PCs attempt to escape, the Sathar fires on them with laser cannons. The first Sathar shots automatically miss. Thereafter, the Sathar has a 20% chance of hitting the XV-1. The XV-1 has 150 structural points. All damage from the Sathar is non-specific. If it is important that the players know, roll on the Weapons Table in the STAR FRONTIERS Expanded Game Rules to see where damage would occur, and tell the players that the XV-1 is partially damaged in that area.

The PCs may be able to bring the XV-1 about and face the Sathar. If they do so, allow them to fight normally, but the Sathar has the option of using all weaponry, save the torpedoes. The Sathar Frigate fired its last torpedo at the XV-1 in the previous encounter when it damaged the XV-1's void drive system.

If the PCs use the vessel to jump backward and put themselves behind the Sathar, allow them to do so. When they shoot from behind, give them two rolls on the Advanced Damage Chart from KNIGHTHAWKSTM to show the severe effects of this unexpected maneuver.

If the PCs have not destroyed the Sathar prior to their fourth hit on the Sathar, the fourth hit will blow up the Sathar Frigate.

Once the Sathar is destroyed, the players automatically find an asteroid which is habitable. They cannot repair void drive or void communication, although they have sublight capability in both areas. They may wait for help, or explore the asteroid while awaiting rescue.

PLAYER CHARACTER STATISTICS

Capt. Dai Llewellyn

Str/Sta 50/50 **Dex/Rs 55/55**
Int/Log 50/50 **Per/Ldr 65/70** **Im 6**

Left-handed human male. Armed with laser pistol, 9 mm service automatic (projectile) pistol, gyrojet pistol and a vibroknife. His skills are: Level 3 beam, projectile and gyrojet weapons, Level 2 thrown weapons, and martial arts; Level 2 operating machinery, detecting alarms, and Level 1 tracking and first aid. He has an albedo suit under his exo-suit (spacesuit).

Gillimk

Str/Sta 45/45 **Dex/Rs 45/45**
Int/Log 40/40 **Per/Ldr 45/45** **Im 5**

He is an ambidextrous Vruskan male who wears an albedo suit and carries a laser pistol and vibroknife. His experience levels are: Level 1 beam and projectile weapons; Level 2 operating machinery, repairing machinery; Level 3 first aid, controlling infection.

Dorf

Str/Sta 55/55 **Dex/Rs 45/45**
Int/Log 35/35 **Per/Ldr 50/50** **Im 5**

Dorf is a Dralosite who wears an albedo suit, carries a laser pistol and vibroknife, and has a permanent "arm/pseudopod" on his right side due to an accident in the Sathar Wars. His experience levels are: Level 1 beam and projectile weapons; Level 2 martial arts; Level 3 making tools/weapons, and empathy.

Viyizzi

Str/Sta 25/25 **Dex/Rs 65/65**
Int/Log 45/45 **Per/Ldr 60/60** **Im 7**

She is an ambidextrous Yazirian female, armed with a laser pistol, automatic pistol, and vibroknife. She wears an albedo suit, and has the following ability levels: Level 4 beam and projectile weapons; Level 3 deactivating alarms; Level 2 tracking, survival, and stealth.

Yoe

Str/Sta 60/60 **Dex/Rs 55/55**
Int/Log 40/40 **Per/Ldr 50/50** **Im 6**

He is an overweight Yazirian male able to "glide" only on the lightest gravity planets, and is right-handed. He carries a laser pistol and a vibroknife, and wears an albedo suit. His experience levels are: Level 1 beam and projectile weapons; Level 2 setting charges, following directions; Level 3 operating machinery and repairing machinery.

Hota Lea

Str/Sta 55/55 **Dex/Rs 50/50**
Int/Log 70/75 **Per/Ldr 40/40** **Im 4**

She is a right-handed human female. She carries a laser pistol and vibroknife and wears an albedo suit. Her experience levels are: Level 1 beam and projectile weapons; Level 2 bypassing security, manipulating programs; Level 3 operating computers, interfacing, and repairing computers; Level 4 repairing robots, altering functions, and altering mission.

NON-PLAYER CHARACTER STATISTICS

Slard

Str/Sta 50/50 **Dex/Rs 40/40**
Int/Log 45/45 **Per/Ldr 50/50** **Im 4**

He is a right-handed human male who wears an albedo suit. He is armed with a laser pistol, a vibroknife, a doze grenade, and a tangler grenade. His experience levels are: Level 1 thrown weapons; Level 2 beam and projectile weapons; Level 3 making tools/weapons.

Violet (V Series Medical Robot)

Im 8 **Base chance to hit: 80%**

Violet is a Level 5 Medical robot with arm-like extensions in the upper torso. The robot's head has vocal, audio, light/infrared, pressure, and sensor circuits for exo-biology. Violet has the equivalent of the following experience levels: Level 5 Medical, Level 4 First Aid, Minor & Major Surgery, Level 3 Control Infection, Cure Disease, Level 2 Neutralize Toxins, Analyze Eco-systems, Level 1 Communication, and Activate Freeze Field. Violet is fitted with a poly-vox, an interface for ship computers, and Level 5 security programs. Violet is used to dealing with Hota Lea, and can be difficult when dealing with other members of the crew if they improperly input information.

ARES is a trademark of TSR, Inc.'s science-fiction gaming section in DRAGON® Magazine. Ares Magazine, the Ares Magazine logo, and Star Frontiers are all trademarks of TSR, Incorporated.

TSR owns copyright to all Ares articles and reserves all rights to them.

Article .html conversion courtesy of Timothy R. Norris

Editing, integration of errata, and .pdf conversion courtesy of Michael A. Kramer

List of Edits/Changes Made During .pdf Conversion:

- 1) Altered XV-1 key and deckplan according to published errata.
- 2) Added stats for Violet the medical robot according to published errata.
- 3) Converted highlighted text to be read aloud to players to boxed text.
- 4) Arranged layout of pages for ease of reading/use when printed and in pdf form.
- 5) Corrected several typos most probably resulting from OCR misreads during initial conversion.
- 6) Reformatted and rearranged statistics blocks into easier to read and use format to speed play.
- 7) Corrected/altered minor items which conflict with canon as follows:
 - a) Paragraph 4 on page 1 stated the *Prachil Star* carried cargos from several **galaxies**; this is doubtful given the size of the frontier and limits given on void jumping. Changed to **systems**.
 - b) Paragraph 4 on page 9 stated that the Sathar wanted the secret of the compact void drive for kamikaze attacks on **PGC** ships, bases, and planets. Do they really have a brand preference? I think not. Changed to **UPF**.

-MAK